

Fertilizer spreaders



[www.kuhn.com](http://www.kuhn.com)

# AXIS

20.1 - 30.1 - 40.1 - 50.1



be strong, be **KUHN**





AXIS

20.1

30.1

40.1

50.1

# UNEQUALLED SPREADING PRECISION!

## YOU WANT HIGH YIELDS...

Controlling your application rate helps your crop yield while monitoring your expenses. KUHN's CDA distribution system is the key for adapting to different requirements, thus optimizing your yield under all possible circumstances.

## MAXIMUM COMFORT...

Ensuring even spreading is a complicated operation. KUHN provides electronic solutions to assist you. Moreover, our focus on easy adjustments further saves your time and avoids errors.

## AND A SPREADER WORKING ACCURATELY

Unique KUHN solutions take care for absolute spreading precision: CDA distribution, GPS control. KUHN's weighing system and EMC-concept for automatic adaptation of the application rate during spreading are unrivalled.

## AXIS fertilizer spreaders in brief:

	Working width	Min/max capacity	Application rate adjustment	Control box
AXIS 20.1	12 to 28 m	1000 to 2300 l	manual / electronic	QUANTRON A (on electronic version)
AXIS 20.1 W	12 to 28 m	1000 to 2300 l	by weighing system and proportional to travel speed	QUANTRON E-2
AXIS 30.1	12 to 42 m	1200 to 3000 l	manual / electronic	QUANTRON A (on electronic version)
AXIS 40.1	12 to 42 m	1200 to 3000 l	manual / electronic	QUANTRON A (on electronic version)
AXIS 40.1 W	12 to 42 m	1200 to 3000 l	by weighing system and proportional to travel speed	QUANTRON E-2 ISOBUS
AXIS 40.1 H-EMC	12 to 42 m	1200 to 3000 l	EMC	ISOBUS
AXIS 40.1 H-EMC-W	12 to 42 m	1200 to 3000 l	EMC and weighing system	ISOBUS
AXIS 50.1 W	18 to 50 m	3000 to 4000 l	by weighing system and proportional to travel speed	QUANTRON E-2 or ISOBUS
AXIS 50.1 H-EMC-W	18 to 50 m	3000 to 4000 l	EMC and weighing system	ISOBUS





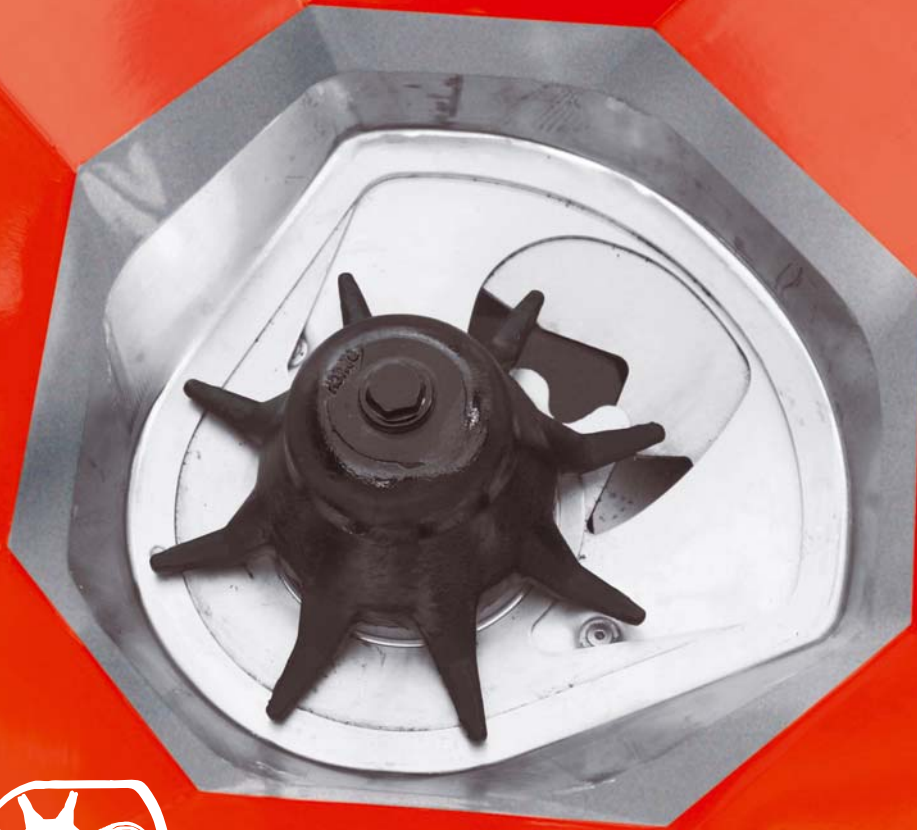

# PRECISE, SIMPLE AND GENTLE

## COMPLETE FLEXIBILITY OF APPLICATION...

Variable fertilizers, differing application rates, changing working widths...fertilizer spreaders must easily adapt to different requirements. The CDA system, part of the entire AXIS range, meets these goals while providing ultra-easy adjustments.

## ...WHILE EVEN SPREADING IS NO ISSUE

How to ensure even spreading across the whole working width even when changing the application rate, the working width or the ground speed, is a big issue for KUHN. The CDA system provides the conditions to ensure optimum lateral distribution patterns.

UREA

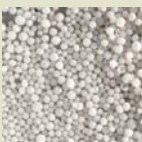

KMg



AMMONIUM  
SULFATE



CAN



NPK



PK



MOUSE BAIT

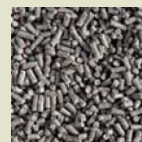

SLUG PELLETS



FINE SEEDS



# EXCLUSIVE CDA: AN UNRIVALLED SYSTEM

There are two important features, which make the CDA (coaxial distribution adjustment) system unique:

1. The pivoting hopper base, which enables a quick adaptation to various fertilizers and working widths by adjusting the drop point.
2. Metering outlets of special design close to the disc centre, allowing a multiple supply to the vanes, thus ensuring a constant fertilizer flow and even spreading.



## THE RIGHT DOSE AT THE RIGHT PLACE

AXIS are the only fertilizer spreaders on the market, which prevent the so-called dose effect, meaning the modification of lateral distribution patterns across the whole width after application rate adjustments. As farmer, you are completely flexible in changing the spreader configuration and can still rely on an unmatched spreading evenness. Check it with the practical test set!

## VARYING APPLICATION RATES HAVE NO INFLUENCE

With the CDA-system, lateral distribution patterns are very regular and precise with large overlap areas and variation coefficients unbeatably low. Also different application rates or travel speeds have no negative effect on fertilizer distribution, as you can see on the diagrams.

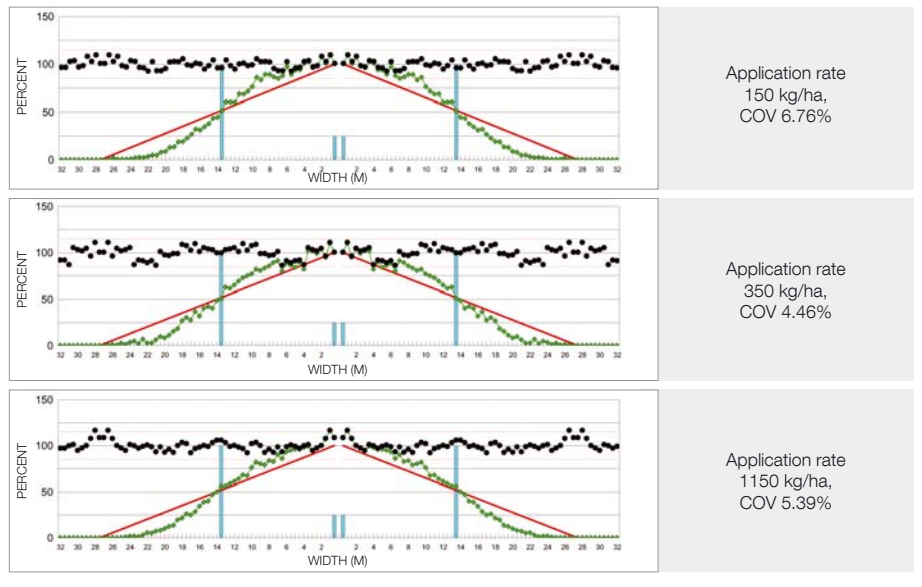

## EXTRA-SLOW AGITATOR

The agitator regulates the disc supply and promotes fertilizer flow. Rotating at only 17 rpm, it treats the granules especially gently.

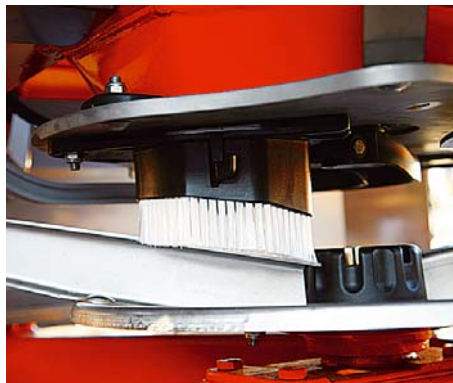

## MORE ACCURACY WITH DROP GUIDE

To ensure an accurate drop point of the fertilizer on the disc, a drop guide follows the fertilizer flow until it is caught by the vanes.

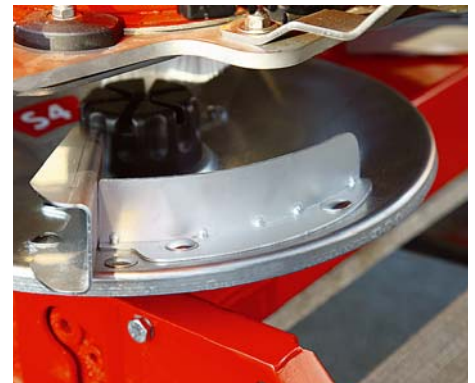

## PATENT

## REDUCE TURBULENCES

AIRFIN deflectors reduce turbulences, which are generated by the rotating discs, thus ensuring an even fertilizer flow.





### SET WORKING WIDTH WITH JUST ONE CLICK!

You modify the working width in a few seconds by simply changing the drop point of the fertilizer onto the disc. This is done without any tools by pivoting the base (manually on AXIS 20.1, 30.1, 40.1; from the cab on AXIS 50.1 W / H EMC). No vanes have to be adjusted, no manual contact with the fertilizer is necessary!

Rotation of hopper base around disc center

1. position for wide working width
2. position for narrow working width

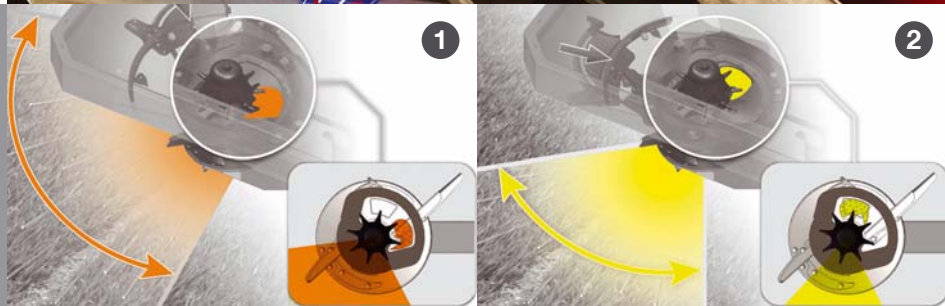

### EXCLUSIVE

#### SETTING APPLICATION RATE INTUITIVELY

Using the DFC (Direct Flow Control) graduated scale to modify the application rate on non-electronic spreaders (AXIS K/D/C) is very easy. After flow control, you can directly change the rates proportionally. Example: Increasing your application rate by 10 % means to enlarge the outlet also by 10 %.

#### SPREAD UP TO 500 KG PER MINUTE!

AXIS spreaders have been designed for working very precise at high travel speeds. Small application rates from 3 kg/ha up to impressing 500 kg/min are possible. This is equivalent to 500 kg/ha at 36 m with 16.5 km/h and clears the way for considerable cost reductions and increasing daily outputs. High-speed spreading and fuel savings: any more demands?





# KUHN Electronics

INNOVATIVE FARMING

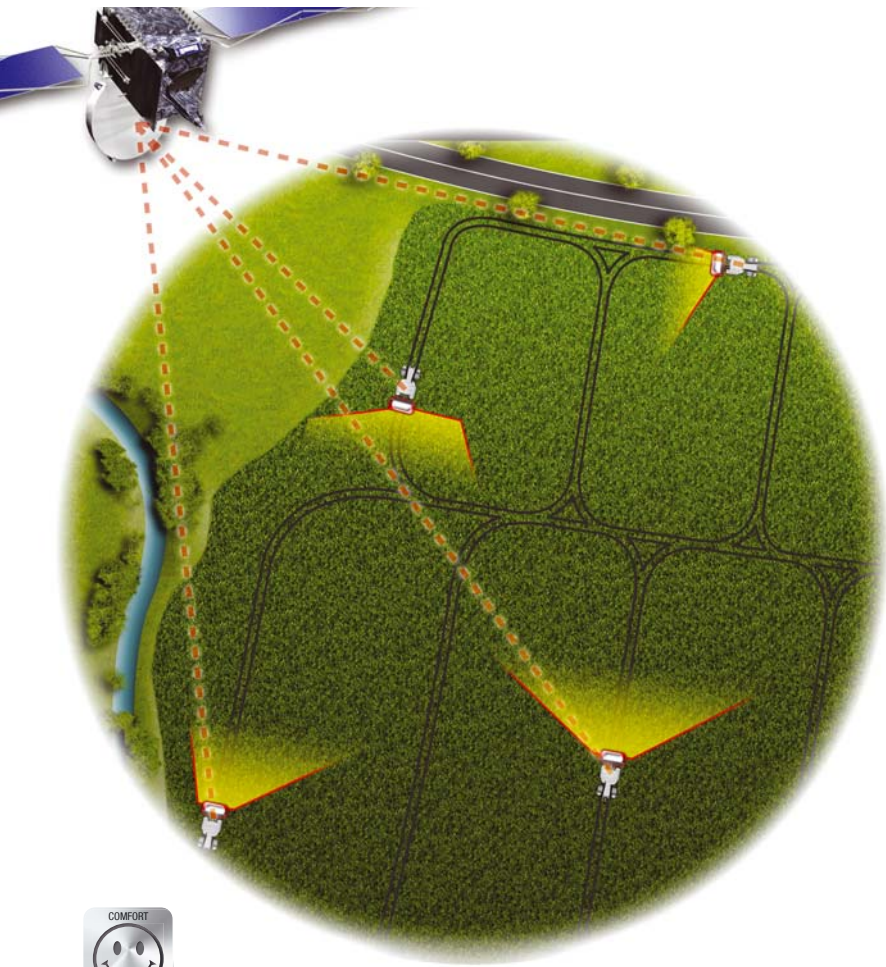

## THE INTELLIGENT FERTILIZER SPREADER

KUHN electronic solutions for AXIS fertilizer spreaders, both ISOBUS and non-ISOBUS, make use of versatile possibilities to increase spreading accuracy as well as the driver's comfort. Don't hesitate to discover the future of farming.



## QUANTRON A/E-2

YOUR SPREADING ASSISTANTS

QUANTRON control boxes electronically adjust the metering outlets and therefore the ground speed related flow rate (D.P.A.E. electronic device) according to pre-set application rate. The latter is always retained at varying speeds. During spreading, the driver is able to:

- modify the application rate,
- switch part-widths for either side,
- close simultaneously either side via a button.

A work counter for 200 fields and integrated spreading charts are additional features. Useful for machinery rings or contractors: It can be used on several tractors!

## ISOBUS

### REDUCE THE NUMBER OF CONTROL BOXES

ISOBUS, the "universal" language allows different equipments (tractor, machine, home computer) to communicate with each other. Thus, you can monitor and transmit information of different machines with one single control box, the KUHN CCI 100 or every other ISOBUS terminal. These are compatible with all ISOBUS machines. Benefit from this maximum of comfort!

As founding member of CCI Competence Center ISOBUS, KUHN is also able to provide useful CCI applications to expand the functions of your terminal. For example CCI Command: Via GPS this app shows you the right track and automatically shuts off sections in field points.



QUANTRON E-2



AXIS H-EMC on CCI 100





## GPS CONTROL



### Automatic headland management and section control

GPS control includes all KUHN solutions for automatic dis-/engagement on headlands or field points. It is provided for spreaders with electronically controlled metering outlets, including all AXIS Q-, W- and EMC-models with according control boxes (QUANTRON A, E-2 or CCI 100 ISOBUS).



Ideal switch points for different fertilizer types

### PRECISE WORKING WIDTH WITH GPS

VARI-SPREAD cares for the right working width at all times by changing:

- spreading disc speed,
- drop point.

Metering outlets are opened and closed with GPS support. Even in field points VARI-SPREAD shuts off sections on left and right at the ideal moment. The result: maximum comfort and highest possible precision.

### FINDING THE IDEAL POINT TO OPEN THE OUTLETS

On headlands most farmers always start spreading at the same moment, though each fertilizer is different. **OPTI-POINT** now automatically determines the ideal point of opening and closing the metering outlets with GPS support for each type separately.



# COMPATIBLE WITH PRECISION FARMING

Precision farming helps optimizing inputs and returns while preserving resources. The concept takes into account differences in crop development or nutrient supply within one field and relies on technologies, such as geospatial tools or GPS (Global Positioning System). Our aim is to make you benefit from these innovative tools, while retaining a maximum ease of use.

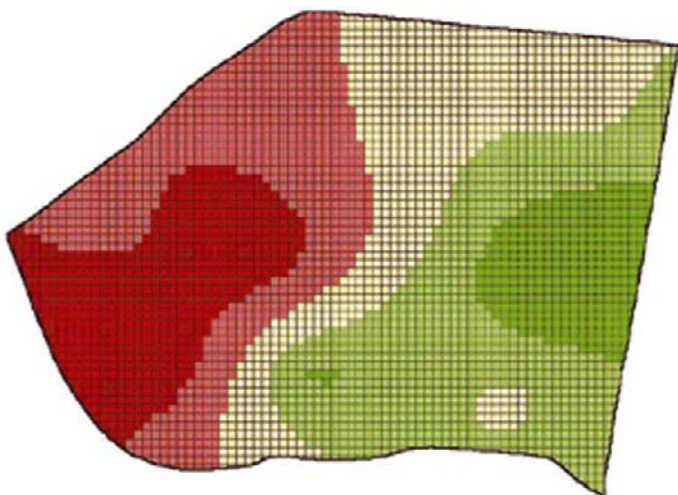
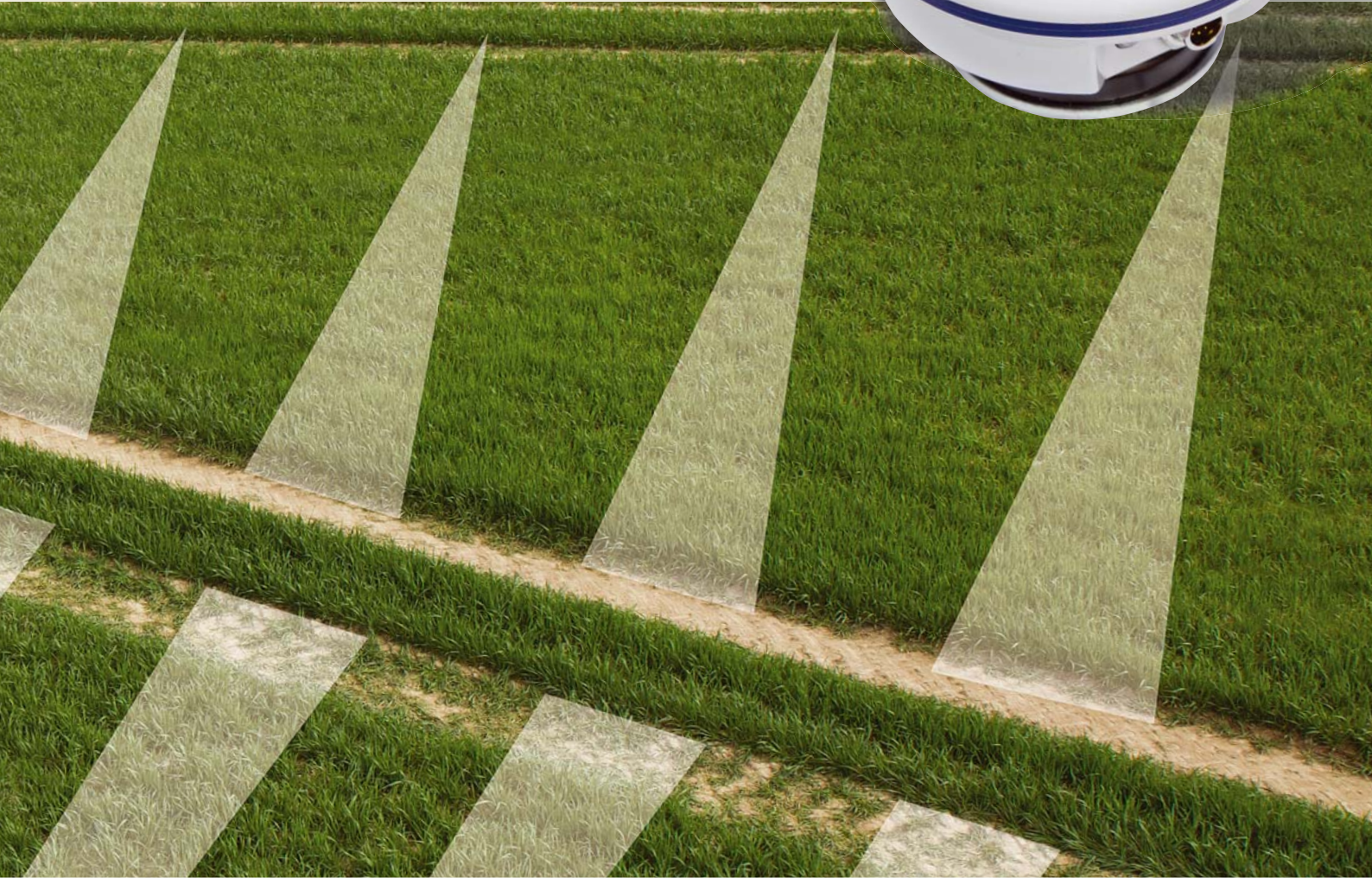

## COMPATIBLE FOR N-SENSOR AND GPS RATE ADJUSTMENT

QUANTRON A and E-2 are compatible with the N-SENSOR to modulate the inputs of nitrogen. Thus, you are able to benefit from your soil's potential while saving significant amounts of fertilizer. The control boxes are pre-equipped for information transfer to and from your home computer.

Also integrate your maps into your GPS: John Deere, Trimble, Sat Plan, RDS, RAVEN, AGROCOM, TOP CON...almost everything is possible. Thanks to the connection cable RS 232, your AXIS fertilizer spreader will adjust the spread rate according to the maps, controlled by GPS.



# WEIGHING SYSTEM: PRECISE „ONLINE“ REGULATION

Two weighing cells in cooperation with electronic units (QUANTRON E-2 or ISOBUS) fulfil the farmer's demand to adapt the application rate automatically during spreading. Every second QUANTRON E-2 (or ISOBUS terminals) checks, if the flow corresponds to the programmed rate, and adjusts it for highest possible precision and controlled comfort.

## FLOW RATE ADJUSTMENT EVERY SECOND!



### PRINCIPLES OF USE

1. Program your work criteria (width, application rate).
2. Load the fertilizer and start spreading.
3. QUANTRON E-2 compares automatically target quantity with actually applied amount of fertilizer (analysis 100 times per second!).
4. In case of irregularities, it adjusts the metering outlets automatically every second.
5. Application rate can be modified anytime by one click.



### OPTIMUM INTEGRATION

The original, patented design of the weighing system consists of a strong hitch frame fitted with two weighing cells with a capacity of ten tons each, and in the upper part, a link rod connected to the machine frame.

### MANY BENEFITS OF THE CLEVER COUPLING SYSTEM:

- two weighing cells: accurate even on slopes
- no increase in the loading height
- two coupling heights available: for late top spreading
- unloaded weight only slightly different (plus 35 kg)
- new A coupling frame: high clearance for drive





# EMC: INDEPENDENT DISC BY DISC

EMC or „Electronic Mass Flow Control“ is a unique technology, well-established and rewarded after years of experience. It measures and continuously adjusts the application rate on each disc separately for all hydraulically driven AXIS models. For those seeking complete flexibility and accuracy.



## NO METERING COMPROMISES

EMC utilizes the fact that pressure differences at the hydraulic disc motors are proportional to the fertilizer flow rate at metering outlets. This is independent of the type of fertilizer. The system carries out following steps:

1. Sensors read the pressure in the system. 2. Pressure is adjusted when deviating from desired flow rate separately for each disc. 3. Metering outlets are corrected automatically according to new data.

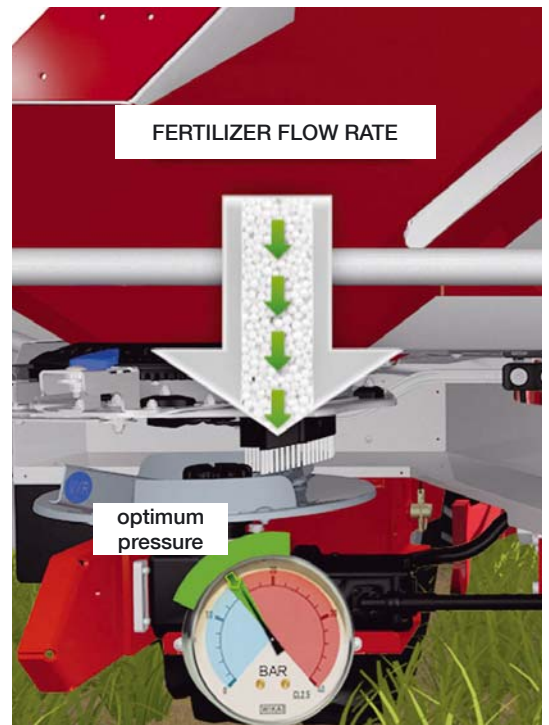
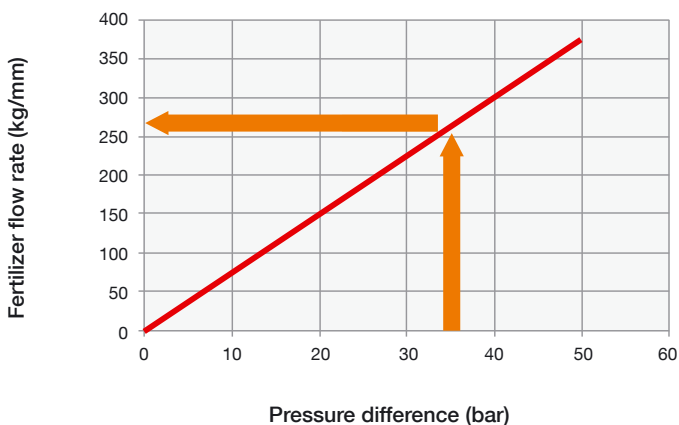

## MORE ADVANTAGES

- individual adjustment of left and right disc every second -
- more fuel efficiency because of reduced engine speed
- neither machine height nor weight increased - insensitive to slopes or changes in forward speed
- no flow tests required - 100 % compatible with a supply hopper

**Need more  
answers about  
how EMC  
works?**

Take a picture of this QR-code with your smartphone to find out.





AXIS	20.1	30.1	40.1
	K-D-C-Q	K-D-C-Q	K-D-C-Q

# SIMPLE AND ACCURATE

The smaller AXIS models provide an unequalled application rate accuracy, quality of fertilizer distribution and easy adjustment. CDA distribution is the clue.

**AXIS 20.1: from 12 to 28 metres**

Thanks to a large choice of extensions, potential hopper capacities of AXIS 20.1 models range from 1000 to 2300 litres. The compact design makes it ideal for use on medium-sized tractors.

**AXIS 30.1-40.1: reduce your spreading time**

These spreaders are designed for highest work outputs. Both ranges are characterized by a modular hopper capacity of 1200 to 3000 litres and working widths from 12 to 42 metres.

**NEW** E-CLICK: shut off by one click

**E-Click** is a simple control box with two levers to open and close the outlets via electric cylinders directly from the cab. No hydraulic valves are needed! The system was designed for small and medium-sized farms.





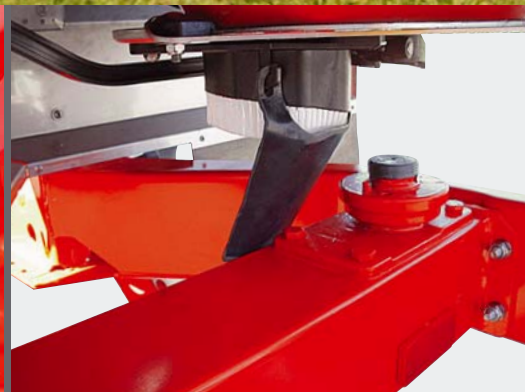

## FOR EVERY FARMER

Dependent on the model the metering outlets are operated differently: - AXIS K: two single acting hydraulic cylinders, - AXIS D: two double acting hydraulic cylinders - AXIS C: two electric cylinders and E-Click - AXIS Q: two electric cylinders and proportional to ground speed (D.P.A.E.);

## QUICK FLOW TEST AND RATE SETTING

With the DFC system, your machine is simply set: Use initially the spreading chart settings. Then remove the disc and fit the chute (stored above disc guard) for a flow test. After collecting the fertilizer, modify the position of the DFC selector according to your needs.

## CHECK IT FROM THE CAB!

QUANTRON A is the standard control box on AXIS Q models. Apart from D.P.A.E., you can benefit also from the user-friendly design and control comfortably from the cab: metering outlets, travel speed, area spread, quantity spread, residual amount of fertilizer;







AXIS

20.1 W

40.1 W

50.1 W

# SOPHISTICATED WEIGHING FOR EVERYONE!

KUHN offers AXIS 40.1 W, 50.1 W, and now also 20.1 W models with the integrated weighing system. Therefore, this innovative and precise technology is available for everyone and every working width from 12 to 50 m.



## More precision means higher return on investment

Linked to the weighing cells, the QUANTRON E-2 terminal records the application rate continually during spreading. In this way it recognizes uneven flow rates, which occur due to speed variations, fertilizer features or changing climatic conditions, and corrects them automatically one time per second. Your advantages: no calibration test needed and non-negligible savings of fertilizer!



### SMALL AXIS - HIGH PRECISION

The AXIS 20.1 now also features the weighing system and addresses demanding cereal farms of smaller size.



### SPREADING POWER UP TO 50 M

With a payload of 3000 or 4000 litres and a working width of up to 50 m the AXIS 50.1 W ensures maximum autonomy and high outputs.



### SIMPLE AND USER-FRIENDLY CONTROL BOX

Programme the application rate, working width and drop point. Then load the machine and you are ready to spread. QUANTRON E-2 takes care of a continuous automatic adjustment „on-line“.



## THE KUHN PLUS

## FLEXIBLE WITH ISOBUS

AXIS 40.1 W and 50.1 W are available as ISOBUS versions as well as all AXIS H-EMC models. Benefit from the advantages of one universal „electronic language“ and run several ISOBUS machines with one terminal. Compatible with GPS control.

AXIS

40.1 H-EMC

40.1 H-EMC-W

50.1 H-EMC-W

# INDIVIDUAL FERTILIZER CONTROL SIDE BY SIDE

The new AXIS H-EMC-(W) range offers a unique combination of innovative technologies to meet the expectations of today's professionals. CDA distribution, ISOBUS options, the hydraulic disc drive and especially the integration of EMC technology for adjusting the application rate separately and continuously for each disc are the main features.

These machines are designed for accurate spreading results without the need of the farmer to get directly involved. He can concentrate on driving.





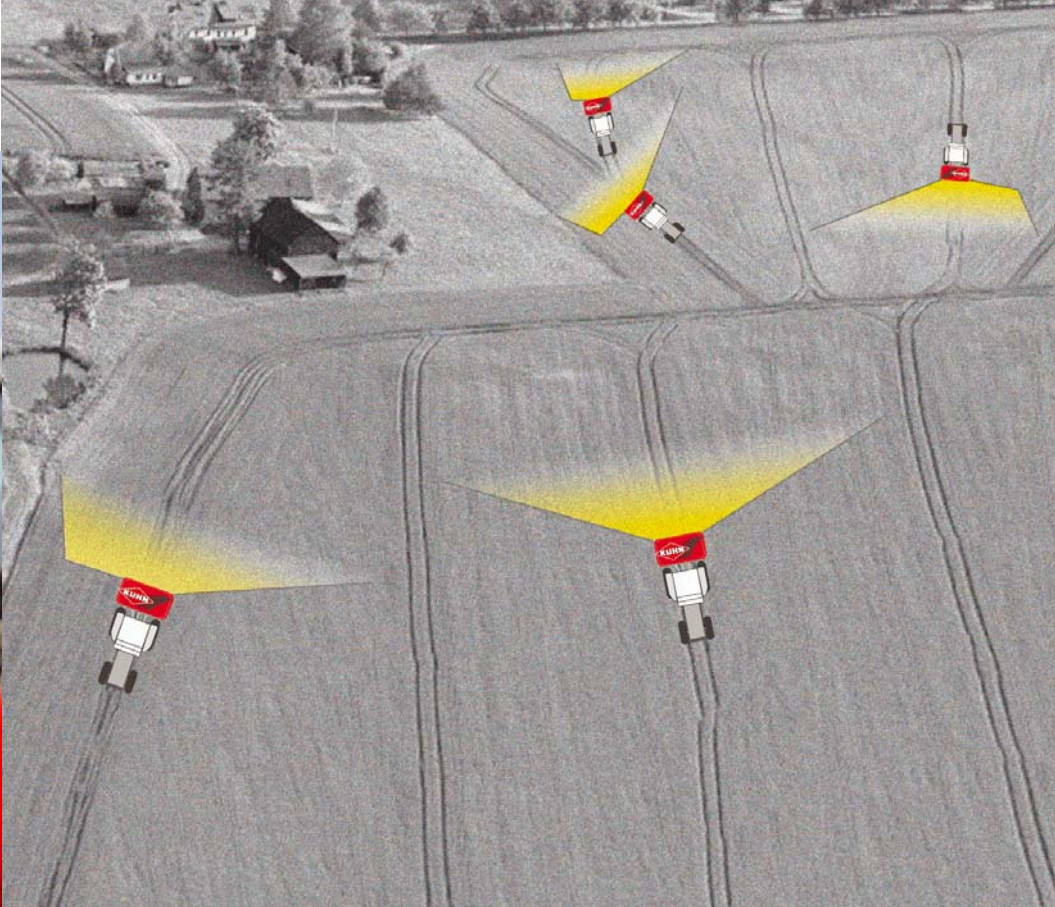
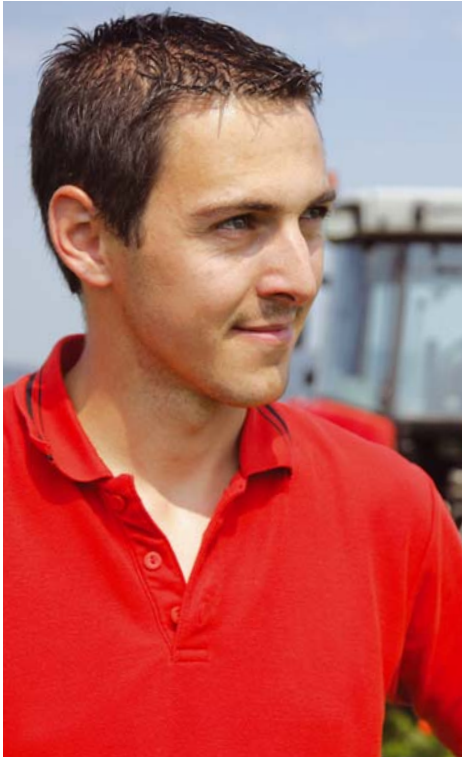

## ADAPT YOUR SPREADING TO FIELD SHAPE WITH GPS

With VARI-SPREAD, working widths on left and right can be adjusted by changing the disc speed and modifying the drop point. Additionally, up to eight sections can be shut off individually, four on each side. The system is standard and fully controllable from the cab with GPS.

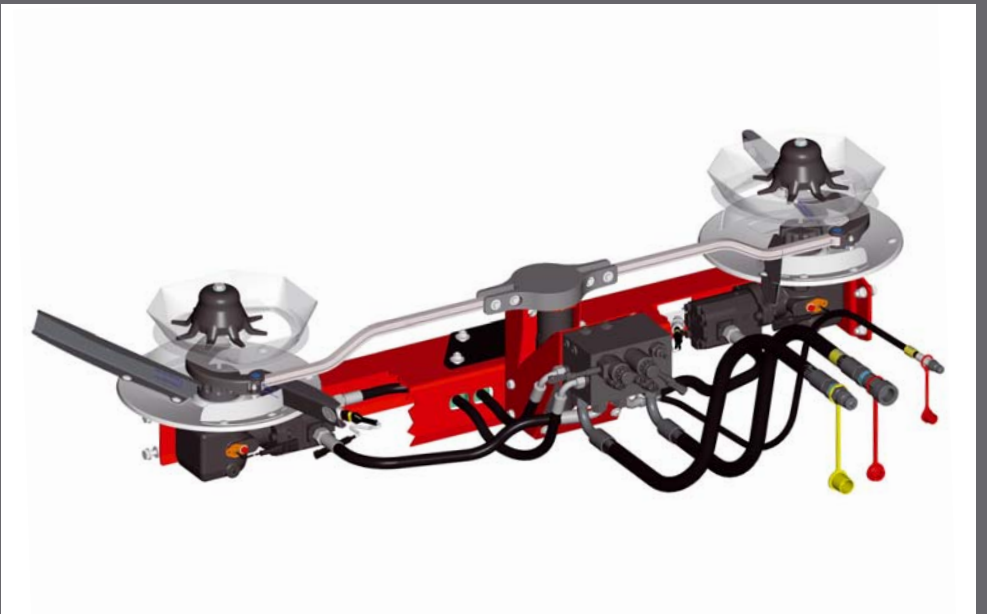

## INDEPENDENT DISC SPEED

The discs, driven by the tractor's hydraulic system, are independent of the motor as well as PTO speed. Therefore their spread pattern remains constant and can be adjusted flexibly when driving to field points. Another advantage for the environment and farmer's wallet: Spreading with reduced engine speed is possible, which decreases fuel consumption.





AXIS

40.1 H-EMC

40.1 H-EMC-W

50.1 H-EMC-W

#### WEIGHING FRAME FOR MORE INFORMATION

Two high-capacity weighing cells inform the driver continuously about the residual fertilizer quantity remaining in the hopper.

#### ELECTRICALLY DRIVEN AGITATOR

The electric drive of the agitator contributes to not damaging the fertilizer. This is, because it stops immediately, when the metering outlets are closed, consequently keeping the granules intact.

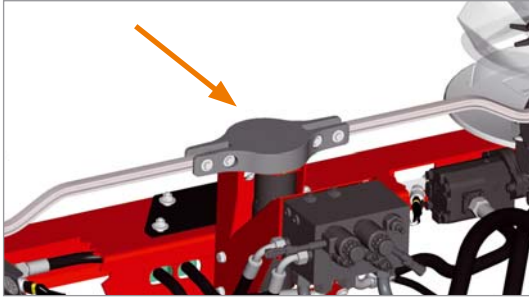

#### COMPATIBLE WITH ISOBUS

All AXIS H-EMC machines are fitted as standard with ISOBUS technology.

Therefore you can directly integrate your spreading maps into the ISOBUS terminal and also use ISOBUS systems from John Deere, Müller Elektronik and Trimble. High level of simplicity and ease of use!

# 100% FROM THE CAB!

## NO MANUAL ADJUSTMENT OF THE VANES!





# KUHN ADVANTAGES FOR EXCEPTIONAL SPREADING



## TRouble-FREE BORDER SPREADING

TELIMAT is a border limiter for boundary or border spreading for AXIS models with mechanical disc drive, used to prevent fertilizer waste and respect environmental instructions. Its deflectors can be positioned and oriented according to working width and type of fertilizer. The trajectory of the granule is modified thereby. The TELIMAT can be set up in total comfort without stopping or disengaging the PTO.



## GSE EQUIPMENT FOR BOUNDARY SPREADING

GSE is available on AXIS models to prevent any fertilizer being spread outside the field. Just precise boundary spreading.



## EVEN LESS MAINTENANCE

- Reduce your maintenance costs through an increase in service life – even including parts, which are subject to more intensive wear:
- hopper base, application rate and spreading components: 100 % stainless steel;
  - reinforced VXR+ vanes coated with tungsten carbide for long service life: standard on S6 to S12 discs (AXIS 50.1), optional on S2 and S4;
  - first gearbox oil change only necessary after ten years;
  - agitator control requiring no maintenance;
  - easy to clean and wash;

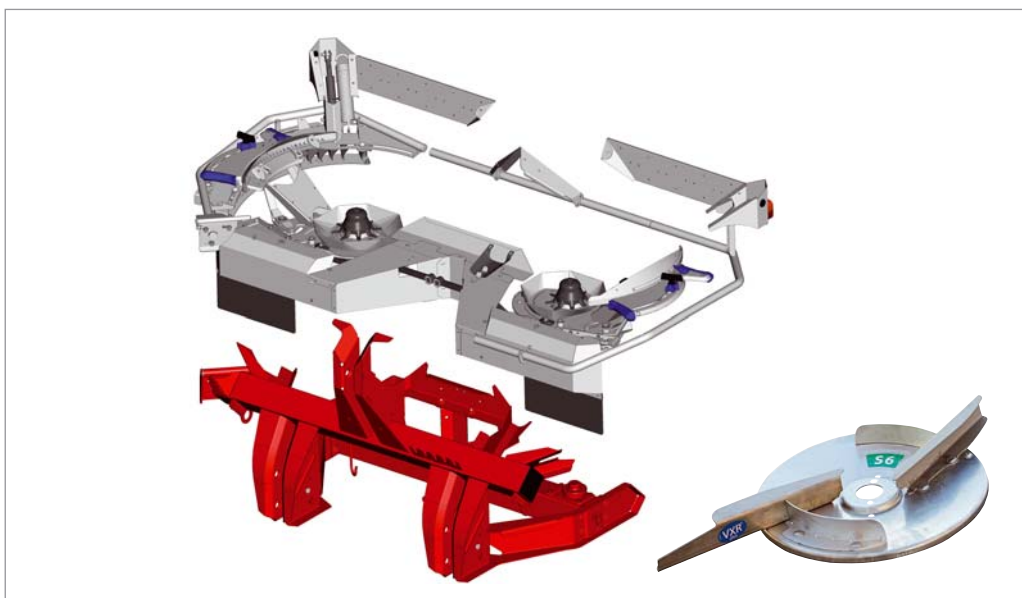





# DETAILS FOR MORE COMFORT



## EASY HOPPER ACCESS

AXIS 40.1 and 50.1 models are equipped with ladders of special design for an easier access to the hopper. As always KUHN sets a high value on security: Therefore the ladder can pivot for usage.



## SEE THE LEVEL OF FERTILIZER

Two openings bringing light inside the hopper, the level of fertilizer is easily visible through the hopper windows!  
Optional equipment: fertilizer level sensors to be directly informed in the cab (as option on AXIS Q and W, as standard on H-EMC).



## MUD PROTECTION

Mudguards, supplied as standard, protect the machine from mud ejected by tractor wheels. An extension is available as option on AXIS 30.1 and 40.1.



## EASY TO ATTACH

Two coupling heights make it easy to attach to tractors of different sizes for easy loading or late top spreading.





### **PRACTICAL PARKING WHEEL**

To be more flexible during coupling and uncoupling of your spreader, a parking wheel is available with quick coupling system.



### **SPEED SENSOR**

Different speed sensors are available for maximum comfort for applying variable rates. As standard either by ISO 11786 plug or by a sensor to be attached on the drive shaft (picture).



### **100 % QUALITY**

A highly sophisticated painting process, many stainless steel components and UV-proof synthetics fulfill highest standards and protect the machine against corrosion.



### **TESTING FOR THE FUTURE**

Many spreading tests have been carried out in our internal test hall to this day. It helps us create spreading charts, increase setting precision and find new technological solutions for your benefit.





# GAIN YOUR INFORMATION ADVANTAGE



**THE KUHNS PLUS**

**IDENTIFY YOUR FERTILIZER FOR PROPER SPREADING**

For fertilizer of unknown origin, the identification guide classifying the different varieties of fertilizer by category, helps you recognise the product and determine the optimal setting.

DIVISION DES GROUPES D'ENGRAIS	
Groupe N :	Engrais N
Groupe NPK :	Engrais NPK
Groupe PK :	Engrais PK
Groupe P :	Engrais P
Groupe K :	Engrais K
Groupe U :	Urée
Groupe USA :	Sulfate d'ammoniaque



**COMPLETE SPREADING CHARTS**

Charts are supplied with the machine. They can also be found on the KUHN website ([www.kuhn.com](http://www.kuhn.com)) under „Online services“. This section is continuously updated with new fertilizers.

## \* KUHN SERVICES: MAXIMIZE THE USE AND PRODUCTIVITY OF YOUR KUHN EQUIPMENT

### KUHN sos order

**Express spare parts service 24/7**

You urgently need spare parts? With KUHN SOS ORDER benefit from express delivery seven days a week, 365 days a year. Thus, you can minimize machine downtime considerably and increase your work output.

### KUHN protect +

**The choice of professionals!**

Benefit from 36 months in complete serenity because of KUHN's PROTECT + warranty. You can concentrate exclusively on your work and the performance of your machine. Because this is what you expect, when investing in high-tech machinery.

### KUHN i tech

**For ever quicker repairs!**

An unexpected technical problem always occurs at the wrong time. Your KUHN dealer can support you quickly and efficiently thanks to KUHNITECH. With this 24/7 online service, a quick and exact diagnosis is possible.

### KUHN finance

**Invest rationally!**

New machine necessary, financing unsure? Modernize your equipment and develop your farm with KUHN FINANCE, in total safety and according to your needs and demands. We offer custom-made finance solutions, adapted to your requirements.





## Technical specifications

## Fertilizer spreaders AXIS

	20.1	20.1 W	30.1	40.1	40.1 W (ISOBUS)	40.1 H-EMC (W)	50.1 W (ISOBUS)	50.1 H-EMC-W
Working width (m/ft)	12-28 (36*) / 39'4"-92" (118'*)		12-42* / 39'4"-138*			18-43 / 59'-142'	18-50* / 59'-164'*	
Min/max capacity (l)	1000 / 2300		1200 / 3000			3000 / 4000		
Maximum load capacity (kg/lbs)	2100 / 4629		3000 / 6614			4000 / 8818		
Weight without extensions (kg/lbs)	290-295 / 639-650	335 / 739	325-330 / 716-725	355 / 782	390 / 860	450 / 992	695 / 1532	
Minimum filling height without extensions (cm/in)	92 / 36"		105 / 41"			149 / 58"		
TELMAT	◇	◆**	◇	◆**			-	
Application rate adjustment	adjustable lever or electronically (Q version)	DPAE electronic control + weighing system	adjustable lever or electronically (Q version)		DPAE electronic control + weighing system	EMC electronic mass control (+ weighing frame)	DPAE electronic control + weighing system	EMC electronic mass control + weighing frame
Outlet control	by hydraulic or electric (on C or Q version) cylinders	by electric cylinders	by hydraulic or electric (on C or Q version) cylinders		by electric cylinders			
Weighing system	-	◆	-	◆	- (◆)	◆	◆	
Hopper cover	◇			◆**				
Control box	QUANTRON A (on Q version)	QUANTRON E-2	QUANTRON A (on Q version)	QUANTRON E-2 or CCI 100 (ISOBUS)	CCI 100 (ISOBUS)	QUANTRON E-2 or CCI 100 (ISOBUS)	CCI 100 (ISOBUS)	

◇ standard  
 ◆ option  
 - not available

\* Only fertilizers included in our spreading charts can achieve the largest working widths.

\*\*The standard equipment depends on the country of destination.

DPAE: ground speed related application rate adjustment.

## Extension type

	L 603		L 800		L 1500*		XL 1103		XL 1300		XL 1800*	
Extension width (m/ft)	2.40 / 7'10"						2.80 / 9'2"					
Extension capacity approx. (l)	600		800		1500		1100		1300		1800	
Total capacity (l) if fitted on basic machine	20.1	30.1-40.1	20.1	30.1-40.1	20.1	30.1-40.1	20.1	30.1-40.1	20.1	30.1-40.1	20.1	30.1-40.1
	1600	1800	1800	2000	-	2700	2100	2300	2300	2500	-	3000
Minimum filling height (cm/in)	92/36	99/39	118/47	125/49	-	149/59	115/46	122/48	129/51	136/54	-	151/59
Extension weight (kg/lbs)	40/88		50/110		85/187		70/154		75/165		85/187	

\* Extensions not compatible with AXIS 20.1 as well as with AXIS 20.1 - 30.1 - 40.1 with LEVSAK.

### Standard equipment:

work on half the width – application rate and spreading components are made of stainless materials – cat. 2 hitch with two height position hitch points - disc rotation guard to conform to Standard EN 14017-A1 – rear road lights (depending on model and country) – filtering sieve – hopper level sight glass (AXIS 30.1 / 40.1 / 50.1) – pto shaft with shear bolt on AXIS 20.1 – pto shaft with cam-type cut out clutch (on AXIS 30.1 / 40.1 / 50.1) – flow control kit - removable, tool-free, quick-release discs – gearbox 540 rpm – agitator control without maintenance – mudguards (AXIS 30.1 / 40.1 / 50.1) – with the QUANTRON E2: speed sensor (to be mounted on the pto shaft of the front axle assembly or wheel) and connection cable to ISO 11786 plug

### Options:

S2 discs for spreading 12 to 18 m (VXR+ version available) - S4 discs for spreading 18 to 28 m (VXR+ version available) – S6 VXR+ discs for spreading 24 to 36 m – S8 VXR+ discs for spreading 30 to 42 m - S10 VXR+ discs for spreading 36 to 44 m (only for AXIS 50.1) – S12 VXR+ discs for spreading 42 to 50 m (only for AXIS 50.1) – vanes for spreading anti-slug pellets - fertilizer level sensors (AXIS Q/W) – TELMAT position sensors (AXIS Q/W) – anti-spray deflectors (AXIS 20.1) – parking wheels – long cables for mounting on a supply tank.





AXIS 20.1 30.1 40.1 50.1

# COMPARE TO FIND THE AXIS MODEL, WHICH EXACTLY FITS YOUR NEEDS!

AXIS

Fertilizer spreaders

	K D C	Q	W	H-EMC	H-EMC-W
Ease of use	+	++	+++	+++	+++
Optimized distribution	+++	+++	+++	+++	+++
Exact application rate adjustment	+++	+++	+++	+++	+++

+++ optimum ++ very good + good o suitable



Twin disc fertilizer spreaders



Pneumatic fertilizer spreaders



Lifting equipment

For more information  
about your nearest KUHN dealer,  
visit our website  
[www.kuhn.com](http://www.kuhn.com)

 <a href="http://www.kuhn.com">www.kuhn.com</a>	Your KUHN dealer
---	------------------

**KUHN S.A.**

4 Impasse des Fabriques - BP 50060 - F-67706 Saverne CEDEX - FRANCE

**KUHN NORTH AMERICA, INC.**

1501 West Seventh Avenue - P.O BOX 167 - Brodhead, WI 53520 - USA

**KUHN FARM MACHINERY PTY. LTD**

313-325 Foleys Road - Deer Park, VIC, 3023 - AUSTRALIA

**KUHN FARM MACHINERY (U.K.) LTD**

Stafford Park 7 - GB TELFORD/ SHROPS TF3 3BQ - GREAT BRITAIN

Some machines have a considerable weight. Respect the tractor gross vehicle weight rating, its lift capacity and maximum load per axle. The tractor front axle load must always reach minimum 20 % of the tractor net weight. Our material is produced in accordance with the European Machinery Directive in the member states of the European Union. In countries outside the E.U., our machinery complies with the safety regulations set by the country concerned. Some safety devices may have been removed from our leaflets in order to clarify the illustration. Under no circumstances should the machine be operated without the necessary safety devices in place (as specified by the assembly instructions and operators manual). We reserve the right to change any designs, specifications or materials listed without further notice. Machines and equipment in this document can be covered by at least one patent and/or registered design. Trademarks cited in this document may be registered in one or several countries.

Also  
find KUHN on

